

Direct Mount, 3-Way Ball Valve



Description

Jomar's 850T - 850L, 3-way, stainless steel ball valve is a three-way diverting valve with ISO 5211 pad for actuator, full port from 1/4" to 2".

Features

- Self adjusting stem packing
- Blow-out proof stem design
- 100% air tested under water at 80 psi
- Working pressure is 1000 psi (1/4" to 1"), 800 psi (1 1/4" to 2")
- Temperature range -20°F to 450°F
- ISO 5211 mounting pad

Warranty

The Company, for a period of one year from the date of shipment, warrants each product or system of its own manufacture to the original purchaser to be free from defects in material and workmanship under normal use, service and maintenance.

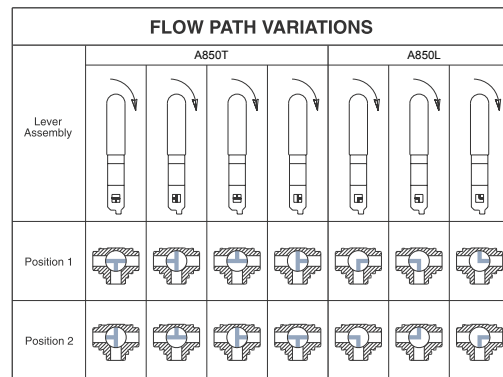

Architect/Engineer approval

Job Name _____ Date _____

Model Specified _____ Quantity _____

Variations Specified _____

Customer/Wholesaler _____

Contractor _____

Architect _____

Note: Information subject to change without notice.



Direct Mount, 3-Way Ball Valve

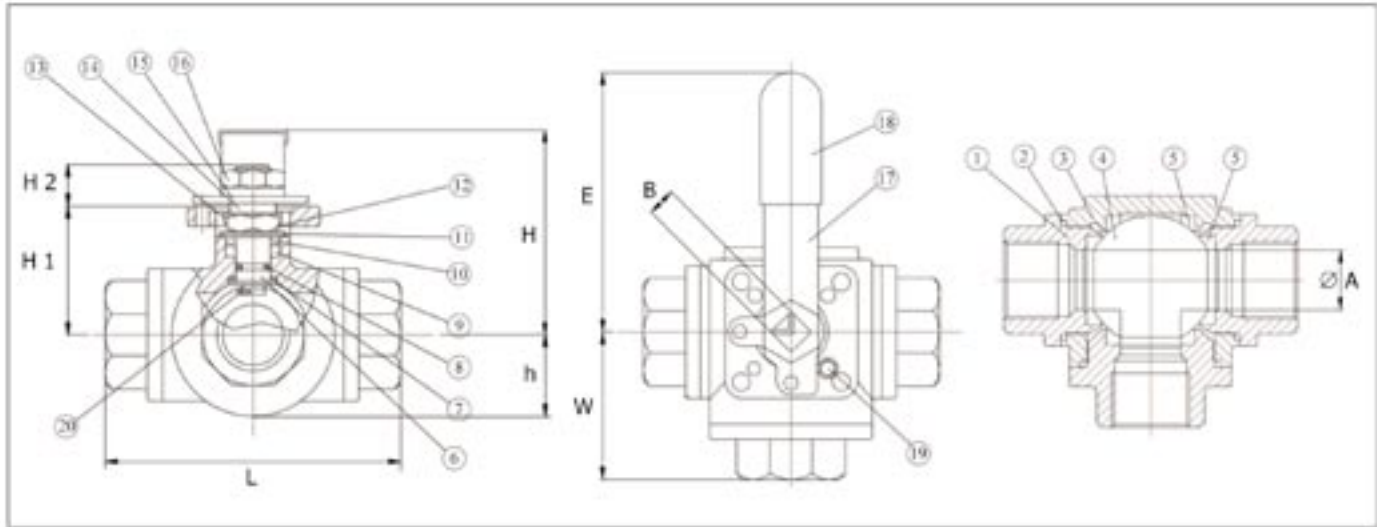
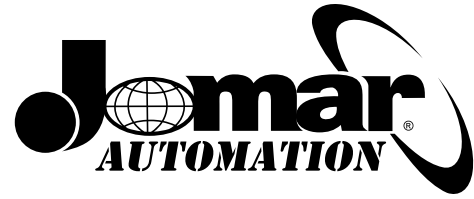

DIMENSIONS (in)

NO.	PART NAME	MATERIAL	N PCS.
1	End Cap	A351 Gr. CF8M	3
2	Gasket	P.T.F.E.	3
3	Body	A351 Gr. CF8M	1
4	Ball	SS 316	1
5	Seat	P.T.F.E./R.P.T.F.E.	4
6	Stem	SS 316	1
7	Stem Seal	R.P.T.F.E.	1
8	O-Ring	Viton	1
9	Stem Packing	P.T.F.E.	1
10	Gland	SS 304	1
11	Belleville Washer	SS 301	2
12	Stem Nut	SS 304	1
13	Nut Stop	SS 304	1
14	Space Washer	SS 304	1
15	Lock Saddle	SS 304	1
16	Handle Nut	SS 304	1
17	Handle	SS 304	1
18	Handle Sleeve	Vinyl	1
19	Stop Pin	SS 304	1
20	Insert Pin	SS 316	1

Full Port	Standard Port	∅ A	B	E	H	H 1	H 2	h	L	W	Wt. (lbs)	Break Torque	ISO5211
1/4"	—	0.43	.35	5.12	2.44	1.45	.40	0.78	2.83	1.41	1.45	105 in/lbs	F03/F04
3/8"	1/2"	0.47	.35	5.12	2.44	1.45	.40	0.78	2.83	1.41	1.41	105 in/lbs	F03/F04
1/2"	3/4"	0.59	.35	5.12	2.51	1.65	.45	0.91	3.26	1.63	1.87	138 in/lbs	F03/F04
3/4"	1"	0.78	.43	6.49	3.22	1.65	.59	1.10	3.89	1.94	3.21	184 in/lbs	F04/F05
1"	1 1/4"	0.98	.43	6.49	3.50	2.18	.55	1.33	4.40	2.20	4.80	323 in/lbs	F04/F05
1 1/4"	1 1/2"	1.25	.55	8.07	3.85	2.48	.64	1.53	4.92	2.46	7.23	461 in/lbs	F05/F07
1 1/2"	2"	1.50	.55	8.07	4.25	2.88	.62	1.88	5.86	2.93	11.55	633 in/lbs	F05/F07
2"	—	2.00	.66	12.79	5.51	3.63	.88	2.36	6.85	3.42	20.89	1,037 in/lbs	F07/F10

Note: Information subject to change without notice.



Jomar International Ltd.
7243 Miller Drive
Warren, MI 48092
Phone: 800-325-5690
Fax: 800-628-4194
www.jomar.com