

A-766L

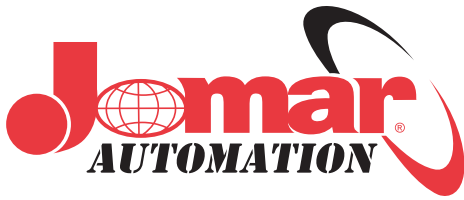

Flanged, Stainless Steel 3-Way Ball Valve



Description

Jomar's A-766L is a compact design, AISI 316 stainless steel, flanged, 3-way ball valve with diverter, two seats and L reduced port.

Features

- Blow-out proof stem, adjustable stem packing
- PTFE seats, packing and thrust washer
- Temperatures to 344° F
- 100% tested
- TUV T.A. Luft approved
- T-port available upon request
- Sizes 1/2" - 4"

Warranty

The Company, for a period of one year from the date of shipment, warrants each product or system of its own manufacture to the original purchaser to be free from defects in material and workmanship under normal use, service and maintenance.

Architect/Engineer approval

Job Name _____ Date _____
Model Specified _____ Quantity _____
Variations Specified _____
Customer/Wholesaler _____
Contractor _____
Architect _____

Note: Information subject to change without notice.



Jomar International Ltd.
7243 Miller Drive
Warren, MI 48092
Phone: 800-325-5690
Fax: 800-628-4194
www.jomar.com

Flanged, Stainless Steel 3-Way Ball Valve

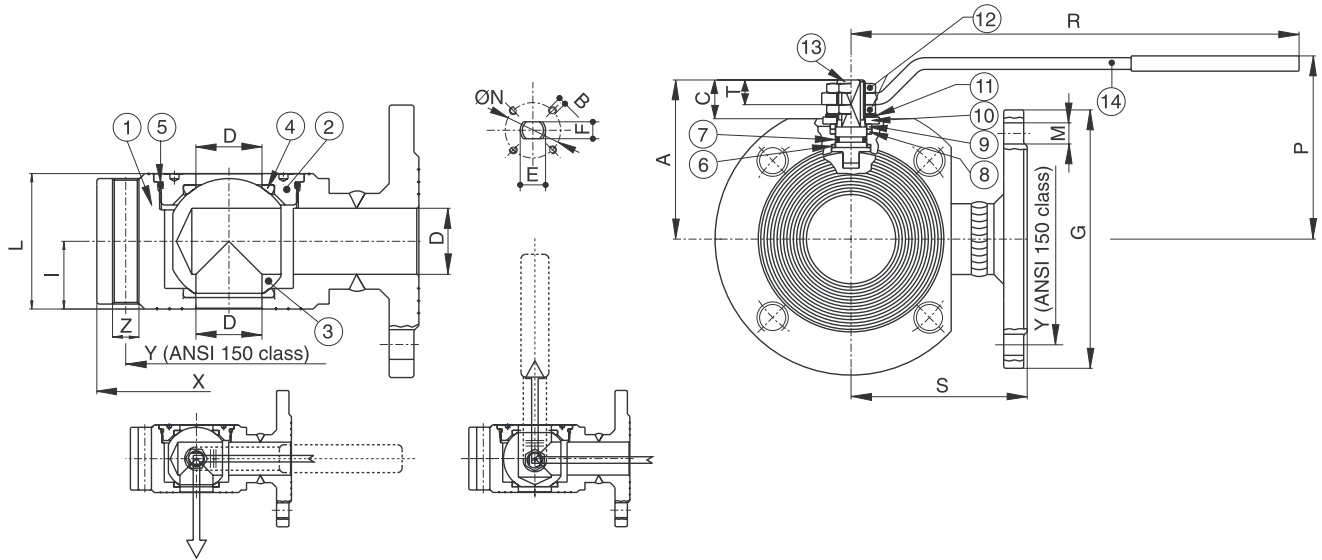
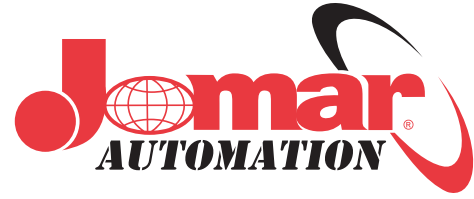

N Pos	PART NAME	MATERIAL	N PCS
1	BODY	AISI 316	1
2	END CONNECTION	AISI 316	1
3	BALL	AISI 316	1
4	BALL SEATS	P.T.F.E	2
5	O-RING	FKM (Viton®)	1
6	THRUST WASHER	P.T.F.E	1
7	O-RING	FKM (Viton®)	1
8	STEM SEAT	P.T.F.E	1
9	PACKING GLAND	STEEL	1
10	END STOP	STEEL (1 1/2" - 2") STEEL (2 1/2" - 8")	2 1
11	SPRING WASHER	STEEL	2
12	NUT	STEEL	2
13	STEM	AISI 316	1
14	HANDLE	STEEL	1

SIZE	X	Y	Z UNC	I	L	R	P	A	C	T	G	M	D	S	E	F	ØN	B	Lbs
1/2"	3.50	2.38	4X1/2"	0.78	1.57	5.17	2.54	1.85	0.61	0.35	3.50	4 X Ø 0.62	0.39	2.99	0.39	0.27	1.26	4XM5	4.91
3/4"	3.88	2.75	4X1/2"	0.78	1.57	5.17	2.71	1.95	0.53	0.35	3.88	4 X Ø 0.62	0.59	3.23	0.39	0.27	1.26	4XM5	6.30
1"	4.25	3.12	4X1/2"	0.90	1.81	6.87	3.17	2.32	0.70	0.49	4.25	4 X Ø 0.62	0.78	3.38	0.47	0.31	1.65	4XM5	8.57
1 1/4"	4.62	3.50	4X1/2"	1.14	2.28	6.87	3.33	2.52	0.61	0.45	4.62	4 X Ø 0.62	0.98	3.93	0.47	0.31	1.65	4XM5	13.69
1 1/2"	5.00	3.88	4X1/2"	1.39	2.79	9.86	4.03	3.07	0.96	0.51	5.00	4 X Ø 0.62	1.26	4.13	0.63	0.39	1.97	4XM6	18.73
2"	6.00	4.75	4X5/8"	1.61	3.22	9.86	4.29	3.35	0.98	0.53	6.00	4 X Ø 0.75	1.57	4.52	0.63	0.39	1.97	4XM6	27.05
2 1/2"	7.00	5.50	4X5/8"	2.08	4.17	12.65	4.29	4.11	1.10	0.71	7.00	4 X Ø 0.75	1.97	4.92	0.78	0.55	2.76	4XM8	44.10
3"	7.50	6.00	4X5/8"	2.40	4.80	12.65	5.37	4.45	1.10	0.71	7.50	4 X Ø 0.75	2.52	5.90	0.78	0.55	2.76	4XM8	53.66
4"	9.00	7.50	8X5/8"	2.99	5.98	15.01	6.12	5.35	1.36	0.86	9.00	8 X Ø 0.75	2.99	6.26	0.94	0.70	4.02	4XM10	84.76

Note: Information subject to change without notice.



Jomar International Ltd.
7243 Miller Drive
Warren, MI 48092
Phone: 800-325-5690
Fax: 800-628-4194
www.jomar.com